

1 Göllerkopf - 40km 2 Jakobsbad - 49,5km 3 Bazora - 25,9km 4 Bömmeli - 50,6km 5 Hirschberg - 70,5km 6 Schwägälp - 51,8km ● building site

01

Station
Bazora

Material
steel

Amount
1

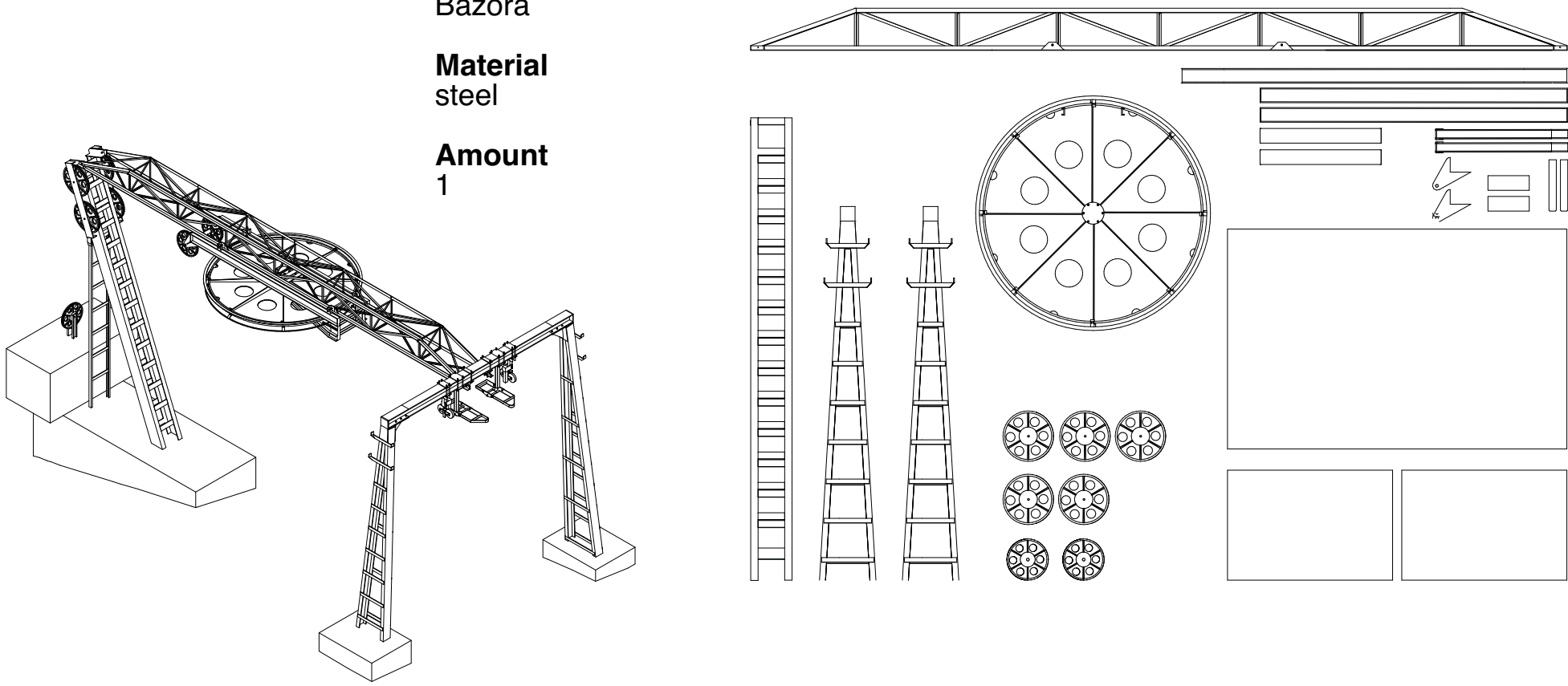

Inventory of Disused Ski Infrastructure

Mapping and analyzing the remnants of alpine ski infrastructure as a resource for architectural transformation.

This inventory compiles and analyzes a series of disused ski lift masts and stations located around the region of Liechtenstein. Once part of a dense network of alpine tourism, these structures have lost their original function as skiing practices, technologies, and climatic conditions have changed. Today, they remain as fragments of an industrial and touristic landscape - technical monuments of a bygone era that continue to shape the visual identity of the alpine terrain.

The marked sites on the map represent former ski infrastructure across Austria and Switzerland, with the most distant one located in Hirschberg, approximately seventy kilometers from Vaduz. Each mast and station has been carefully documented through axonometric drawings that deconstruct the systems into their fundamental components - steel frames, wheels, cables, and concrete bases. All parts are drawn at a consistent scale of 1:66, allowing for a comparative understanding of their material composition and proportional relationships.

The collected material forms an analytical foundation for a broader architectural exploration: how can disused ski infrastructure be upcycled, reinterpreted, and integrated into a new design for a Ski Museum and Visitor Center in Vaduz? Through this lens, the inventory becomes more than a technical record - it acts as a design tool that bridges documentation and transformation. By visualizing the hidden logic, structure, and potential of these remnants, the project seeks to rethink how obsolete infrastructures can contribute to sustainable and context-sensitive architectural futures in the alpine landscape.

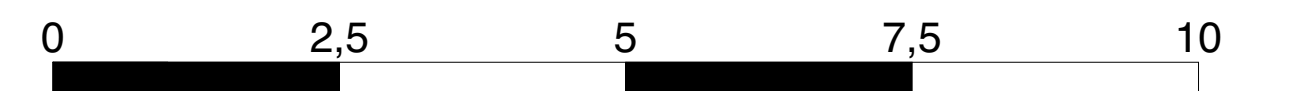

02

Ski lift
Schwägälp

Material
steel

Amount
2

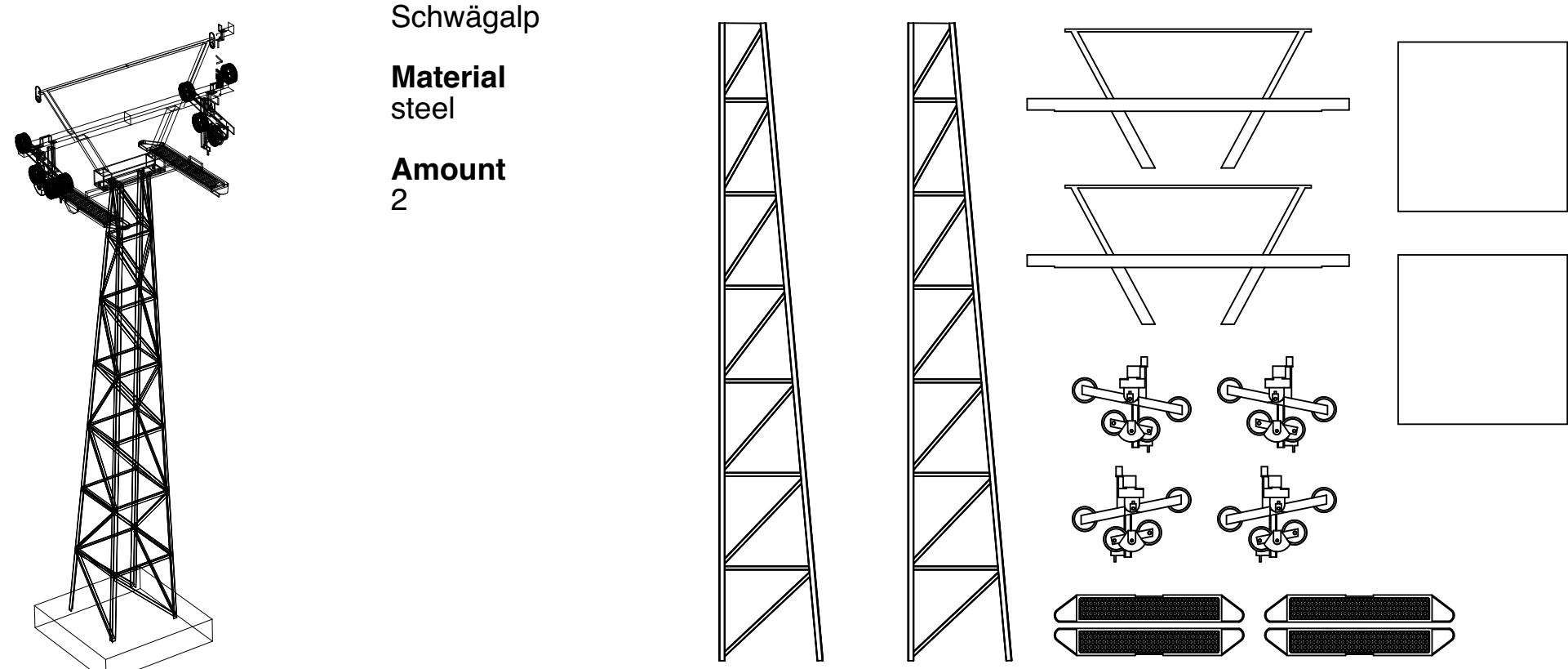

04

Station
Hirschberg

Material
steel

Amount
1

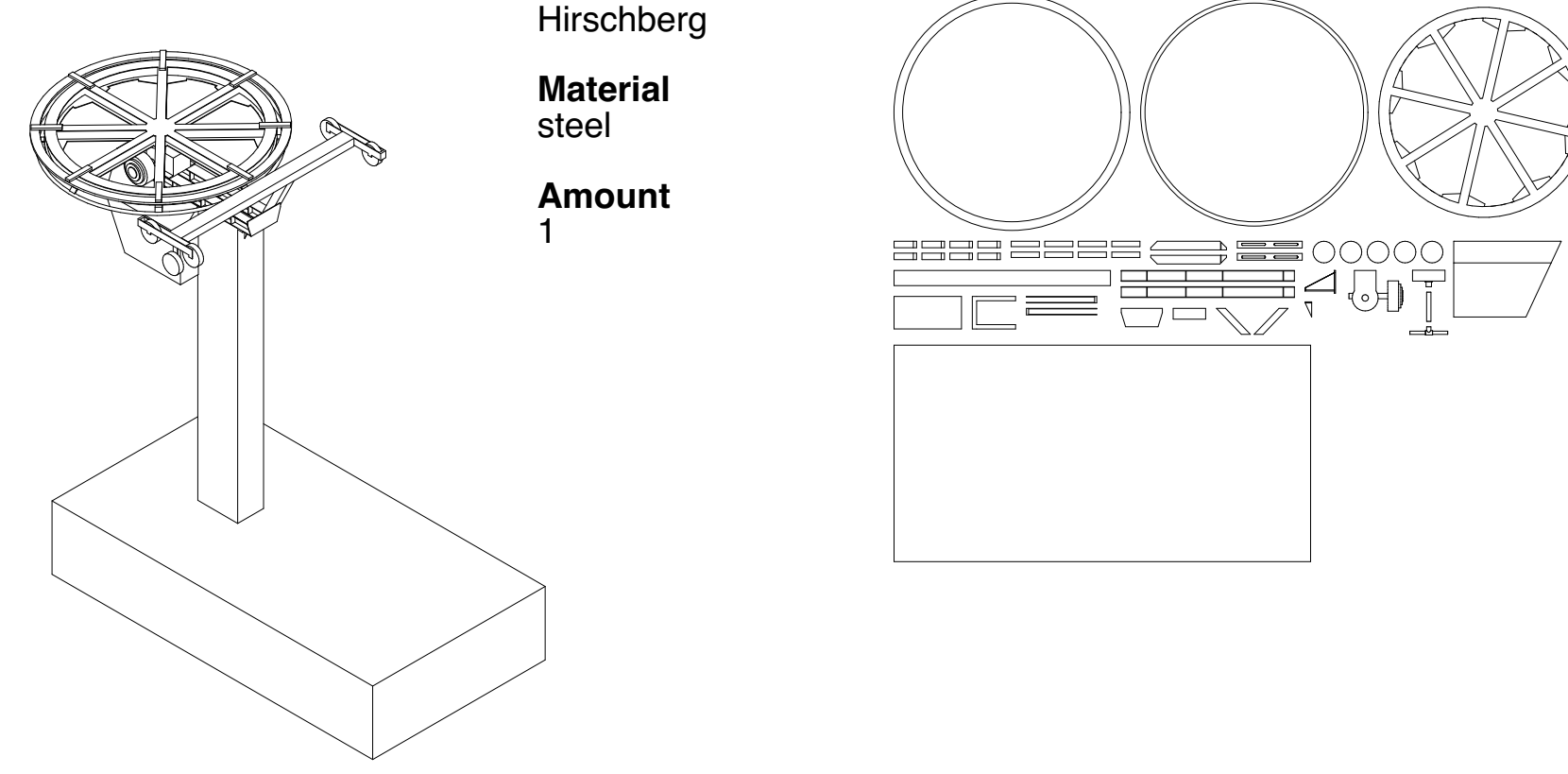

03

Station
Göllerkopf

Material
steel

Amount
1

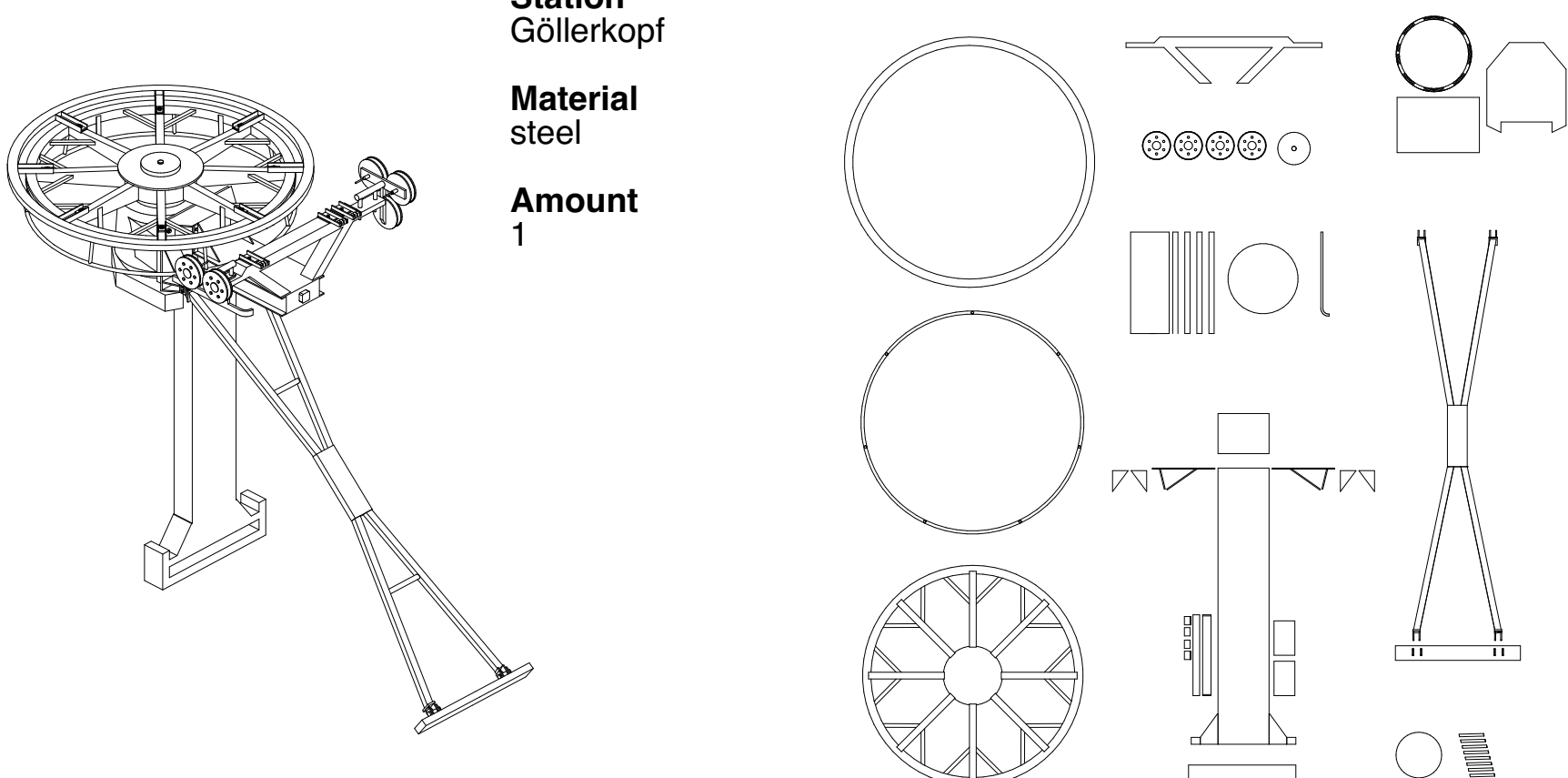

05

Ski lift
Hirschberg

Material
Steel

Amount
2

